

**COLF 8**

Colonna 2 ante con ripiano superiore,  
2 contenitori estraibili multiuso,  
tavolo estraibile,  
cantina laterale estraibile  
64X60X210 h.

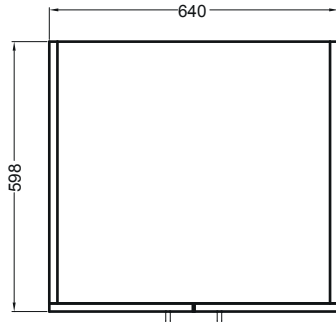

PIANTA

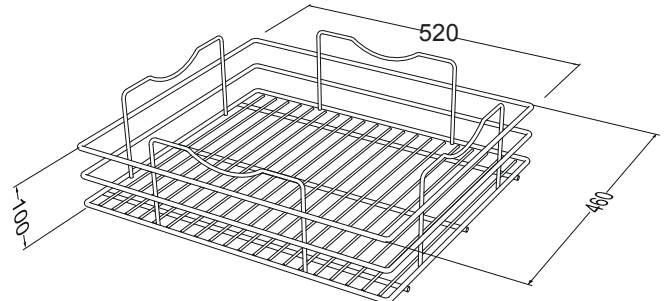

CESTO ESTRAIBILE

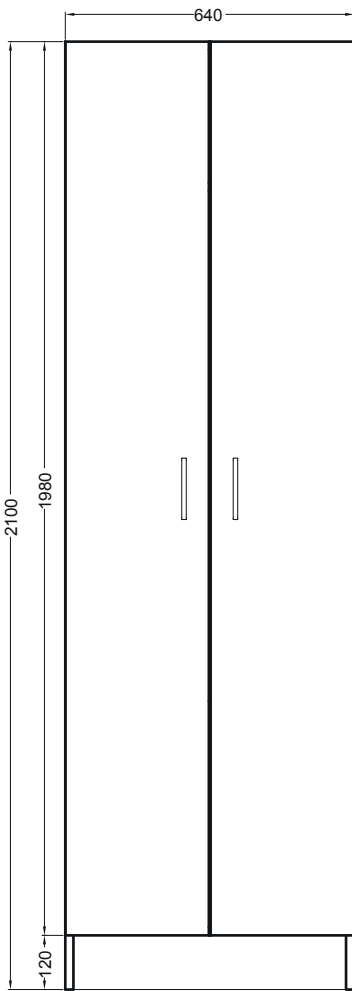

VISTA FRONTALE

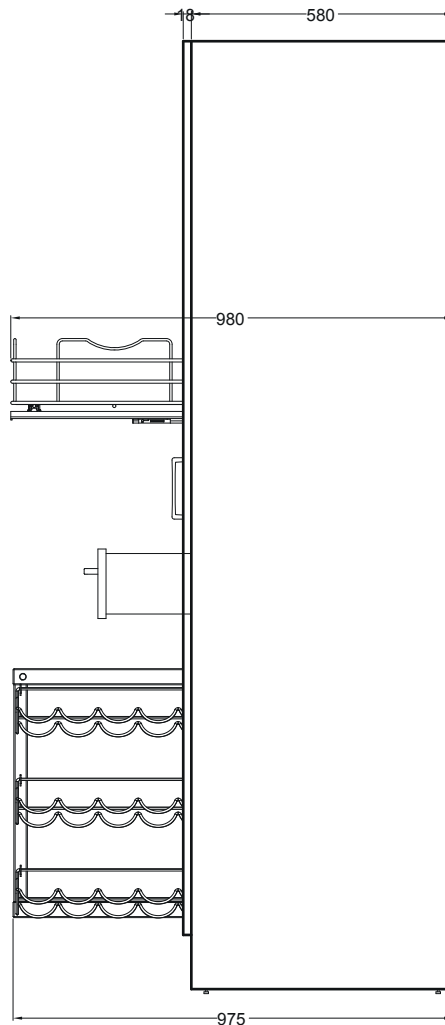

VISTA LATERALE

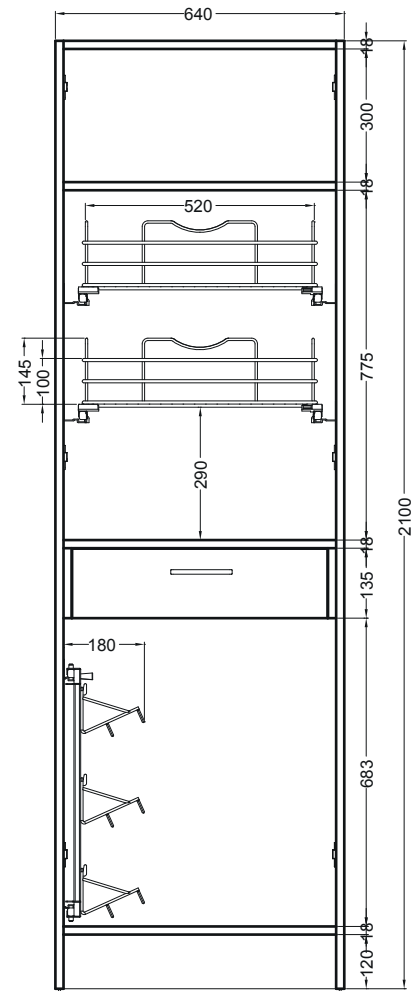

VISTA FRONTALE SENZA PORTE